

Foreword

The formulation of this national standard was initiated by the Agricultural Machinery Testing and Evaluation Center (AMTEC) under the project entitled “Enhancing the Implementation of the AFMA Through Improved Agricultural Engineering Standards” which was funded by the Bureau of Agricultural Research (BAR) of the Department of Agriculture (DA).

This standard has been technically prepared in accordance with PNS 01-4:1998 (ISO/IEC Directives Part 3:1997 – Rules for the Structure and Drafting of International Standards. It specifies the general requirements for the construction of biogas plant.

The word “shall” is used to indicate requirements strictly to be followed in order to conform to the standard and from which no deviation is permitted.

The word “should” is used to indicate that among several possibilities one is recommended as particularly suitable, without mentioning or excluding others, or that a certain course of action is preferred but not necessarily required.

In the preparation of this standard, the following references were considered:

Aguilar, Francisco X., How to Install a Polyethylene Biogas Plant.

Biogas Generation, Noncon Energy Report of the NCED, EUMB, Department of Energy.

Biogas Plants, Gobar Gas Company, Nepal.

Biogas Technology, UNDP-ESCAP-FAO-CHINA Biogas Training Course. The Asian-Pacific Regional Biogas Research-Training Center, Chengdu, China, 1983.

Chinese Biogas Digestion, Selective Dissemination of Science and Appropriate Technology Information in the Philippines. Science and Appropriate technology Information Services, PCATT-SATIS Technology Information Network, Batangas City, Philippines.

ISAT – AT information: Biogas.

Environment: A system approach to biogas technology, June 1997.

Rodriguez, Lylian and T. R. Preston, Biodigester installation manual. University of Tropical Agriculture Foundation Finca Ecologica, University of Agriculture and Forestry, Thu Duc, Ho Chi Minh City, Vietnam.

Rokai Pig Farm Demonstration Biogas Plant, Kaunas, Lithuania, 2000.

Tambong, Arthur It., Biogas Plant Design, April 1992.

Agricultural Structures - Biogas Plant

1 Scope

This standard specifies the minimum requirements for the design and construction of a biogas plant utilizing animal wastes.

2 Reference

The following normative document contains provisions which through reference in this text constitute provisions of this National Standard:

PAES 414:2002 Agricultural Structures - Waste Management Structures

3 Definition

For the purpose of this standard, the following definitions shall apply:

3.1**biogas plant**

plant used to process animal wastes or manure to produce biogas and sludge consisting of an inlet/mixing tank, digester, gas chamber and outlet/sludge tank

3.2**integrated plant**

biogas plant where the digester and gas chamber form one unit

3.3**split-type plant**

digester and gas chamber form separate units

3.4**multi-digester plant**

plant with series of digesters

3.5**floating type**

plant consisting of digester and a moving, floating gasholder that either float directly in the fermenting slurry or in a separate water jacket

3.6**fixed type**

closed digester with an immovable, rigid gas chamber and a displacement pit

3.7

balloon type

plant consisting of a heat-sealed plastic or rubber bag (balloon), combining digester and gasholder

3.8

collecting tank

holding tank

chamber where manure and water are collected, stored and separated from heavy and non-biodegradable materials before feeding them into the digester

3.9

inlet pipe

serves as conveyor of the manure-water mixture or slurry from the mixing tank to the digester

3.10

digester

biodigester

bio-reactor

anaerobic reactor

any water and air tight container designed for the process of anaerobic microbiological degradation of organic matter into which the slurry is introduced for digestion and methanization

3.11

baffle board

division in the digester that prevent the slurry from premature exit into the sludge/outlet tank

3.12

stirrer

mixer

agitator

mechanical device inside the digester used to stir the slurry

3.13

gas chamber

space inside or outside the digester for the collection and storage of biogas

3.14

gasholder retainer

cantilever beam that holds the gasholder/movable cover in position at the desired biogas pressure

3.15

outlet pipe

serves as conveyor where the effluent or the slurry is forced out

3.16

backfill

layer of compacted soil and gravel to support the digester wall

3.17**loading rate**

amount of slurry fed per unit volume of digester capacity per day

3.18**substrate**

organic material used to produce biogas

3.19**seeding**

adding or introducing anaerobic bacteria to the digester

3.20**slurry**

mixture of manure and water

3.21**freeboard**

difference in height between the digester wall and the filling line

3.22**filling line**

level of slurry when the digester is at full load

3.23**retention time**

average period that a given quantity of slurry is retained in the digester for digestion

3.24**toxic materials**

materials that inhibit the normal growth of pathogens in the digester such as mineral ions, heavy metals and detergents

3.25**methanization**

digestion

various processes that take place among the methanogens, non-methanogens and substrates fed into the digester as inputs

3.26**methanogens**

anaerobic bacteria that act upon organic materials and in the process, produce biogas

3.27

mesophilic temperature range

temperature range of 20 °C – 40 °C where mesophilic bacteria operates

3.28

gas production rate

amount of biogas produced per day per cubic meter of slurry

3.29

biogas

mixture of gas (composed of 50 to 70 percent methane and 30 to 40 percent carbon dioxide) produced by methanogenic bacteria

3.30

scum

layer of floating material (mainly fibrous) on the slurry

3.31

sludge

settled portion or precipitate of the slurry; a mud-like, semi-solid mass

3.32

effluent

residue that comes out at the outlet after the substrate is digested/processed inside the digester

4 Classification

4.1 According to plant set-up

4.1.1 Integrated

4.1.2 Split-type

4.2 According to number of digester

4.2.1 Single-digester

4.2.2 Multi-digester

4.3 According to gas chamber design

4.3.1 Floating type

4.3.2 Fixed type

4.3.3 Balloon type

- 4.4 According to feeding method
 - 4.4.1 Continuous-Feed
 - 4.4.1.1 High-Rate Mixed
 - 4.4.1.2 Intermittently Mixed
 - 4.4.1.3 Unmixed
 - 4.4.2 Batch-Feed, Mixed or Unmixed
 - 4.4.3 Hybrid
- 4.5 According to buried position
 - 4.5.1 Ground digester
 - 4.5.2 Semi-buried digester
 - 4.5.3 Underground digester
- 4.6 According to geometrical shapes
 - 4.6.1 Rectangular type
 - 4.6.2 Cylindrical dome type
 - 4.6.3 Square type
 - 4.6.4 Ellipsoidal type
 - 4.6.5 Spherical type
 - 4.6.6 Octagonal type
 - 4.6.7 Dome top type
 - 4.6.8 Inverted dome type
 - 4.6.9 Rectangular dome type
 - 4.6.10 Cylindrical tube type

5 Location

- 5.1** Biogas plant should be located at a site with good drainage.
- 5.2** It should be located as near as possible to the animal pen and should be lower than elevation of animal pen canal.
- 5.3** The utilization of biogas should be near.
- 5.4** Soil foundation should be stable and away from tree roots intrusion.

6 Size of biogas components

6.1 Collecting tank volume

6.1.1 For continuous-fed biogas plant, the size of the tank for collecting and separating manure from heavy and non-biodegradable materials should not exceed to the total slurry volume for 10 days. Table 1 shows the estimated daily quantity of animal manure.

6.1.2 The slurry volume is the volume occupied by the manure and water at a ratio of 1:1 (1 kg of manure: 1 L of water).

Table 1 - Estimated daily quantity of available manure

Animals	Manure available kg/day/animal
Pigs	
Porker, 3-8 months old, mixed ages	2.20
18-36 kg	2.55
36-55 kg	5.22
55-73 kg	6.67
73-91 kg	8.00
Cow	
Feedlot animal	14.0
Breeding animal	13.0
Work animal	7.50
Buffalo	
Breeding animal	14.0
Work animal	8.00
Horse	
Breeding animal	13.50
Work animal	7.75
Chicken	
Layer, 6 months or older	0.075
Broiler, day-old to 8 weeks	0.025

6.1.3 For batch-fed, the slurry input rate shall be multiplied by the interval of slurry charging.

6.1.4 Calculation of optimum dimension should follow the same procedure used for digester tank.

6.2 Inlet pipe

The minimum diameter of the inlet pipe shall be 0.2 m.

6.3 Digester volume

6.3.1 Slurry volume

The digester tank capacity is calculated from the daily slurry volume multiplied by the retention time (Table 2).

6.3.2 Retention time

Table 2 – Retention time for animal manure for mesophilic temperature range

Substrate	Retention time days
Liquid pig manure	15 – 25
Liquid cow/carabao manure	20 – 30
Liquid chicken manure	20 – 40
Animal manure mixed with plant material	50 – 80

6.3.3 Optimum cross-section of a digester plant

6.3.3.1 Floating type

6.3.3.1.1 Table 3 shows the summary of recommended ratios for different cross-section of a floating type.

Table 3 – Optimum height/length ratios of digesters and tanks (freeboard excluded) for volume up to 70 m³ and wall thickness of up to 25 cm

Horizontal Cross-section	Height/Length Ratio, r (Height/Diameter or Height/side)	
	Floating Type (Integrated) Plants and Open Tanks	Floating (Separate Gasholder) and Fixed Type Plants
Circular	0.500	1.00
Square	0.500	1.00
Rectangular ^a		
L = 1.2W	0.455	0.91
L = 1.4W	0.420	0.84
L = 1.6W	0.385	0.77

^a Coefficient of W is the desired length/width proportion, p

Table 3 (continued)

Horizontal Cross-section	Height/Length Ratio, r (Height/Diameter or Height/side)	
	Floating Type (Integrated) Plants and Open Tanks	Floating (Separate Gasholder) and Fixed Type Plants
Rectangular ^a		
L = 1.8W	0.360	0.72
L = 2.0W	0.340	0.68
L = 2.5W	0.295	0.59
L = 3.0W	0.260	0.52
L = 3.5W	0.235	0.47
L = 4.0W	0.215	0.43
L = 5.0W	0.185	0.37

^a Coefficient of W is the desired length/width proportion, p

6.3.3.1.2 If baffle board is provided, it shall be located midway between the inlet and outlet pipes and extends from wall to wall. The height should range from 25% - 50% of the height of the filling line. The height of the filling line should be calculated by subtracting the freeboard from the digester height. If there is no freeboard, filling line is equal to digester height.

6.3.3.2 Fixed type

6.3.3.2.1 The digester and gas chamber is integrated into one tank. The total height of the plant depends on the sum of the digester and gas chamber volume. Eighty percent of the total digester volume is occupied by the slurry.

6.3.3.2.2 For optimum dimension ratio, refer to Table 3.

6.3.3.3 Balloon type

The digester volume is 80% of the total digester volume is occupied by the slurry.

6.4 Gas chamber volume

6.4.1 The volume of gas production potential should be calculated by multiplying the amount of manure by its gas production rate. Annex B (Table B.4) shows the gas yield for various manure at different retention time.

6.4.2 For floating type, the effective gas chamber volume should depend on the gas production and gas consumption. It should be calculated by getting the product of accumulation rate of biogas and the longest duration when all non-continuous devices are simultaneously idle. The product should be multiplied by 1.3 to account for the 30% fluctuation in biogas production. Biogas accumulation rate is the difference between the biogas production potential less the biogas consumption of each devices.

6.4.3 For fixed type and balloon type, about 20% of the total digester volume is occupied by the gas generated.

6.4.4 For cost minimization, effective gas volume should also be calculated by getting the daily biogas production less the daily biogas consumption.

6.4.5 Annex J shows the type and biogas requirements of various appliances.

6.5 Outlet pipe

The minimum diameter of the outlet pipe shall be 0.2 m.

6.6 Outlet tank volume

6.6.1 For floating and balloon type, the minimum of volume of the outlet tank shall be equal to the daily slurry input of the digester.

6.6.2 For fixed type, the volume of the outlet tank shall be 1/3 of digester volume occupied by the slurry.

6.6.3 Calculation of optimum dimension should follow the same procedure used for digester tank.

7 Functional requirement

7.1 Collecting tank

7.1.1 Concrete channels shall be provided from the source of substrate to the collecting tank with a minimum slope of 2%.

7.1.2 The tank should be concreted and a sluice gate should be provided to control or allow the proper mixture of water and manure.

7.1.3 The floor of the mixing tank should be inclined from 8.5% - 17.5% toward the inlet pipe and it should be elevated at least 0.2 m from the filling line.

7.1.4 A cover made of G.I. sheet shall be provided.

7.2 Inlet pipe

7.2.1 Concrete pipe (prefabricated RC pipe) should be used and it should be inclined 58% with digester wall.

7.2.2 Lower end of inlet pipe should be positioned below the gasholder retainer for floating type. If there is no retainer, the lower end should be located 100 mm from the floor of the digester.

7.2.3 For balloon type, the inlet pipe shall be directly connected to the plastic skin of the balloon. The pipe should be inserted to one half of its length in the interior of the plastic tube and the plastic tube shall be folded around it and shall be secured around the pipe.

7.2.4 The inlet pipe shall be sealed.

7.3 Digester

7.3.1 Fixed and Floating type

7.3.1.1 Digesters should be made of ferrocement, metal, adobe, bricks, reinforced concrete, or reinforced CHB.

7.3.1.2 For reinforced digester, reinforcement shall be a minimum of 10 mm diameter RSB spaced at 0.15 m (both the curved and the horizontal bars) and the curved bars shall be anchored at the top beam. All reinforcement bars shall be secured and tied together with GI wire.

7.3.1.3 More steel reinforcements shall be used for larger digester volume.

7.3.1.4 The concrete walls of the digester shall be reinforced with G.I. chicken wire mesh before plastering with class A mortar mixed with sealing compound or water-proofing compound. Plaster shall be applied in three layers (13 mm, 6 mm, and 6 mm thick). Each layer shall be applied continuously and should be finished within one day. All corners of the digester shall be curved.

7.3.1.5 Floors, beams and foundation shall withstand the maximum load and shall be made of reinforced concrete.

7.3.1.6 Access to the digester should be through the manhole or through the outlet chamber. If a manhole is used as the access inside the digester, it should be constructed in the center of the dome and it should be tightly sealed. Manhole cover should be 0.65 m in diameter and 0.125 m thick.

7.3.2 Balloon type

7.3.2.1 A trench should be dug out from the ground to protect the digester from any damage (from wild and domestic animals) and to help to maintain an appropriate environment for the production of biogas.

7.3.2.2 The sides and floor of the trench should be smooth with no protruding stones or roots, which could damage the plastic film.

7.3.2.3 The floor shall have a slope of about 2.5% from the inlet to the outlet

7.3.2.4 Balloon should be made of red mud plastic, natural polyethylene plastic tube, heat-sealed plastic or rubber balloon where the upper portion serves as the gas storage. In setting the balloon digester, it should be made of two layers of snugly fitted plastic.

7.3.2.5 The plastic tube shall be at least 200 microns.

7.4 Agitator/Stirrer

7.4.1 Natural agitation is recommended for small, low-cost and simple biogas plant.

7.4.1.1 The continuous feeding of a biogas plant can impart motion to the rest of the slurry (Figure 1).

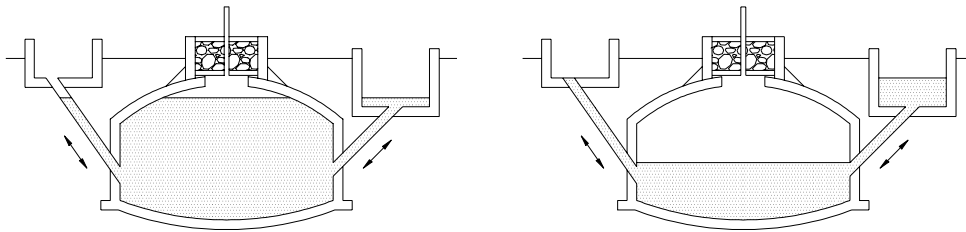

Figure 1 – Mixing substrate through inherent flow in fixed-dome plants

7.4.1.2 Other kind of agitation occur as biogas is formed in the sludge layer at the bottom layer, the gas forces the sludge particles to rise to the surface, where they are released and the then particles will fall back to the sludge layer.

7.4.1.3 Natural agitation occurs when the sludge is heated. The hotter slurry will tend to rise within the body of the cooler slurry.

7.4.2 Mechanical agitation should be provided for larger biogas, floating and balloon plants several times a day to:

- to avoid and destroy swimming and sinking layers,
- to improve the activity of bacteria trough release of biogas and provision of fresh nutrients,
- to mix fresh and fermenting substrate in order to inoculate the former, and
- to arrive at an even distribution of temperature thus providing uniform conditions inside the digester.

7.4.2.1 Agitation should be performed as much as necessary but as little as possible. Annex F shows the various methods of mixing the substrate.

7.5 Gas chamber

7.5.1 Floating-drum plant

7.5.1.1 The gas drum should consist of 2.5 mm mild steel sheets for the sides and 2 mm sheets for the top. It should have a welded-in brace, which break up the surface scum. The drum should be protected against corrosion with suitable coating (oil paints, synthetic paints and bitumen paints).

7.5.1.2 If the floating-drum is made of 20 mm wire mesh-reinforced concrete or fiber cement, it shall have gas-tight internal coating. PVC drums should not be used.

7.5.1.3 The gas drum should have a sloping roof (16.5% slope) and it should be provided with guide frame.

7.5.1.4 The sidewall of the gas drum shall be as high as the wall above the support ledge. Guide frame shall be provided to prevent the floating drum to come into contact with the outer wall and to allow the gas drum to be removed for repair.

7.5.1.5 The depth of liquid jacket should be about 95% of the height of the gasholder and it shall not be less than 300 mm.

7.5.1.6 If the gasholder is too light or too heavy to maintain the desired gas pressure, external weight shall be provided.

7.5.1.7 U-tube manometer should be provided to indicate the relative amount of gas in storage within the biogas plant.

7.5.2 Fixed dome plant

7.5.2.1 The concrete dome shall be reinforced with screen before plastering with class A mortar mixed with sealing compound. Plaster shall be applied in three layers (13 mm, 6 mm, and 6 mm thick). It should be applied continuously and should be finished within one day.

7.5.2.2 The gas chamber shall be capable of withstanding an internal pressure of 0.15 bar.

7.5.2.3 The top part of a fixed-dome plant shall be painted with a gas-tight layer ('water proofer', latex or synthetic paints).

7.5.2.4 A weak-ring in the masonry of the digester should be provided to reduce the risk of cracking of the gas chamber. This should be placed between the lower (water-proof) and the upper (gas-proof) part of the hemispherical structure.

7.6 Gas Outlet pipe

7.6.1 Gas outlet pipe shall be provided and it shall be connected to outgoing biogas valve. Ball valves or cock valves should be used. It should also be installed at all gas appliances as shutoff devices.

7.6.2 Sealed T-joints should be connected before and after the main valve to test the digester and the piping system for their gas-tightness separately.

7.6.3 Gas escape valve prepared from three pieces of PVC pipes should be provided, one arm of the T-joint is connected from the gas outlet and the other arm links to the pipe which goes to the kitchen. The T-joint is inserted in the bottle and water is added to a depth of 40mm - 50 mm above the lower point of the T. Sides of the bottle should be punched with small holes with a height equal to the desired level of pressure to be maintained.

7.6.4 Piping system connects the biogas plant to the gas appliances or to the gas reservoir. Gas reservoir should be made of plastic or steel.

7.6.5 Piping system should be made of G.I. pipes or PVC pipes.

7.6.6 PVC pipes are susceptible to UV radiation and can easily be damaged; hence, PVC pipes should be placed underground. If the site is located in an area with high intensity of sunlight, G.I. pipe should be used.

7.6.7 PVC should be laid at least 0.25 m deep underground. It should be placed in a sand bed and be covered with sand or fine earth.

7.6.8 Table 4, shows the recommended pipe diameters depending on the flow-rate of biogas through the pipe and the distance between biogas digester and gas appliances.

**Table 4 - Pipe diameter for different pipe lengths and flow-rate
(maximum pressure loss <5 mbar)**

		Galvanized steel pipe mm			PVC mm		
Length	m	20	60	100	20	60	100
Flow-rate	m ³ /h						
	0.1	12.7	12.7	12.7	12.7	12.7	12.7
	0.2	12.7	12.7	12.7	12.7	12.7	12.7
	0.3	12.7	12.7	12.7	12.7	12.7	12.7
	0.4	12.7	12.7	12.7	12.7	12.7	12.7
	0.5	12.7	12.7	19.0	12.7	12.7	12.7
	1.0	19.0	19.0	19.0	12.7	19.0	19.0
	1.5	19.0	19.0	25.4	12.7	19.0	19.0
	2.0	19.0	25.4	25.4	19.0	19.0	25.4

7.6.9 If there are turns and bends in the piping system and used for indoors, heavy-duty hose with ply should be used. The minimum diameter should be 13 mm and if used in outdoor, it should be protected from high sunlight exposure.

7.6.10 Piping system should be laid out in a way that allows a free flow of condensation water from moisture-saturated biogas back into the digester.

7.6.11 If depressions in the piping system cannot be avoided, water traps shall be installed at the lowest point of depressions with a minimum inclination of 1%.

7.6.12 Flame arrester shall be provided. It should be made of a ball or roll of fine copper wire mesh inserted in the gas line and it should be located near the digester and near to the point of gas use.

7.7 Outlet pipe

7.7.1 Concrete pipe (prefabricated RC pipe) should be used with a minimum diameter of 200 mm and it should be inclined 58% with digester wall.

7.7.2 For the fixed type, the upper end of the outlet pipe should be level with the bottom of the auxiliary chamber to allow the drawing back of slurry when the pressure decreases.

7.7.3 For balloon type, the outlet pipe shall be directly connected to the plastic skin of the balloon. The pipe should be inserted to one half of its length in the interior of the plastic tube and the plastic tube should be folded around it and should be secured around the pipe.

7.7.4 For the floating type, the upper end of the outlet should be elevated from the floor of the sludge tank.

7.7.5 The outlet pipe shall be sealed.

7.8 Outlet tank

7.8.1 The chamber should be made of concrete with smooth finish. Steel reinforcement may be used.

7.8.2 The chamber shall be provided with a cover made of ordinary or corrugated GI sheets.

7.8.3 Overflow should be provided with the height of at least 100 mm lower than the lower surface of the gas chamber. It should flow into farmland of the plant owner or flow into the lagoon for further treatment.

7.8.4 The height of the floor of the chamber from the filling line shall be at least equal to the operating pressure for appliances using biogas or the height should be at least 0.2 m from the filling line plus 15% freeboard.

7.9 Ground water drainage

7.9.1 If the water seeps from bottom of the excavated pit, blind drain shall be constructed. It should be filled with gravels or chip of tiles, with central sump and take water away manually or by pump.

7.9.2 If water seeps from wall of the excavated earth bank, circular drain outside the location of digester wall shall be constructed to lead water away to sump or some lower places.

7.9.3 In case groundwater is in great quantity, deep wells should be constructed 2 m away from the excavated pit, with a depth 0.8 m – 0.1 m lower than the pit, then pump water away from wells.

7.9.4 In case of too much water and shifting sand sunken barrel shall be used.

7.10 Facilities of a biogas plant

7.10.1 Heating systems

7.10.1.1 If the temperature of the substrate is below the proper process temperature, heating system is recommended.

7.10.1.2 Heating should either be direct heating in the form of mixing hot water to the slurry or indirect heating using heat exchanger located either inside or outside the digester.

7.10.2 Pumps

7.10.2.1 If the amount of substrate requires fast movement, to mix the substrate and when the gravity cannot be used for reasons of topography or substrate characteristics, use of pumps is recommended.

7.10.2.2 Centrifugal pumps for liquid substrate or rotary pumps for substrate of less than 8% solid content or positive displacement pumps for substrate with higher solid content may be used.

7.10.2.3 Pump delivery lines should be made of steel, PVC (rigid), PE (rigid or flexible), or flexible pressure tubing made of reinforced plastic or rubber.

8 Safety considerations

8.1 Visual check

Cracks, gap and tightness of duct in the digester inner wall should be carefully checked using wooden hammer. If vacant sound was heard in a certain area, there is some warping in plastering. Leak trace for wall should be check by spreading some cement powder over the surface, the wet spot or wet line proves that there is leak hole or leak crack.

8.2 Water-holding mark

The digester should be filled with water up to the inlet and outlet pipes level. Allow it to set for 3-5 hours until the walls are saturated with water and mark the water level. Set it for overnight, if there is significant drop in water level, it indicates that there are leaks or cracks.

8.3 Air tight method

After water tightness test, gas test should be followed. Manhole and gas valves should closed and sealed. Add water through the inlet to increase the air pressure inside the digester up to 0.4m of water column. Or air may be blown into the digester up to the same pressure. Leave it for 24 hours, if the pressure drop is about 10 mm - 20 mm, the digester is gas tight. But if the pressure drop is about 50 mm, the dome is not gas tight.

9 Sludge management

9.1 The digested slurry should be either spread on the fields before the beginning of the vegetation period or further conditioned.

9.2 The sludge should be channeled to a sludge conditioning facilities where the solid component is separated and sun-dried while the liquid part is aerated to oxidize the toxic component. For the detailed effluent handling of biogas plant, refer to **PAES 414:2002** Agricultural Structures - Waste Management Structures.

Annex A
(informative)

Digestion process

Stage 1 – Hydrolysis

The waste materials of plant and animals origins, which consist mainly of carbohydrates, lipids, proteins, and inorganic materials are solubilized into simpler ones with the help of extracellular enzyme released by the bacteria.

Stage 2 – Acidification

The monomer such as glucose, which is produced in Stage 1, is fermented under anaerobic condition into various acids with the help of enzymes produced by the acid forming bacteria. At this stage, the acid-forming bacteria break down molecules of six atoms of carbon into molecules of less atoms of carbon which are in more reduced state. The principal acids produced in this process are acetic acid, propionic acid, butyric acid and ethanol.

Stage 3 – Methanization

The principal acids produce in stage 2 are processed by methanogenic bacteria to produce methane.

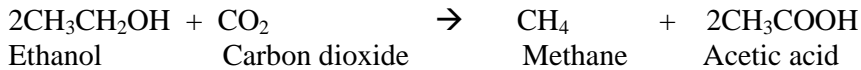
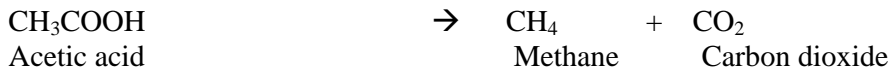

Annex B
(informative)

Digestion process parameters optimization

B.1 Temperature

For anaerobic fermentation, mesophilic temperature range should be 20°C – 40°C, with temperature fluctuations of $\pm 1^\circ\text{C/h}$.

B.2 pH value

The pH value should normally take on a value between 7 – 8.5, if pH value drops below 6.2, the medium will have a toxic effect on the methanogenic bacteria.

B.3 Available Nutrient

Substrates should contain adequate amount of carbon, oxygen, hydrogen, nitrogen, sulfur, phosphorous, potassium, calcium, magnesium and a number of trace elements (Table B.1).

Table B.1 – Nutrient content of common animal excrements

Animal	P ₂ O ₅		K ₂ O	
	kg/a	%	kg/a	%
Cow	34	0.2	84	0.5
Pig	56	0.4	35	0.3
Chicken (fresh droppings)	194	1.0	108	0.6
Chicken (dry droppings)	193	4.6	106	2.5

B.4 Inhibitory factors

Small quantity of mineral ions stimulates the growth of bacteria, while heavy concentration of these ions will have toxic effect. Table B.2 shows the limit concentrations for various inhibitors.

Table B.2 - Limiting concentrations for various inhibitors of biomethanization

Substance	Concentration mg/l
Copper	10 – 250
Calcium	8000
Sodium	8000
Magnesium	3000
Nickel	100 – 1000
Zinc	350 – 1000
Chromium	200 – 2000
Sulfide (as sulfur)	200
Cyanide	2

B.5 Nitrogen content and C/N ratio

B.5.1 For anaerobic digestion of organic materials, a carbon/nitrogen ratio should be within the range of 1:20 – 1:30. The C/N ration should not be more than 1:35.

B.5.2 Materials with high C/N ratio should be mixed with those of low C/N ratio to bring the average ratio of the composite input to a desirable level. Table B.3 shows the value of C/N ratio for different biodegradable material.

Table B.3 – C/N ratio and nitrogen content of some organic materials

Biodegradable material	N %	C/N
A. Animal dung		
<input type="checkbox"/> Hog	2.8	13.7
<input type="checkbox"/> Carabao	1.6	23.1
<input type="checkbox"/> Cow	1.8	19.9
<input type="checkbox"/> Chicken	3.7	9.65
<input type="checkbox"/> Duck	0.8	27.4
<input type="checkbox"/> Pugo	5.0	6.74
B. Household waste		
<input type="checkbox"/> Nightsoil	7.1	6.72
<input type="checkbox"/> Kitchen waste	1.9	28.60
C. Crop residues (air-dry)		
<input type="checkbox"/> Corn stalks	1.2	56.6
<input type="checkbox"/> Rice straw	0.7	51.0
<input type="checkbox"/> Corn cobs	1.0	49.9
<input type="checkbox"/> Peanut hulls	1.7	31.0
<input type="checkbox"/> Cogon	1.07	-
<input type="checkbox"/> Bagasse	0.40	-
D. Others		
<input type="checkbox"/> Kangkong	4.3	7.8
<input type="checkbox"/> Water lily	2.9	11.4
<input type="checkbox"/> Grass trimmings	2.5	15.7

B.6 Gas production potential

Table B.4 – Gas production potential of various types of manure in m³/kg

Manure	Retention Period days			
	25	30	35	50
Pig	0.058	0.063	0.068	0.077
Cow	0.030	0.034	0.037	0.043
Buffalo	0.030	0.034	0.037	0.043
Horse	0.045	0.051	0.056	0.065

Chicken	0.060	0.065	0.069	0.078
---------	-------	-------	-------	-------

Annex C
(informative)

Excavation and backfilling

C.1 Excavation procedure if the digester is underground.

C.1.2 Excavation for digester should be vertical as possible. A 0.15 m minimum gap on both sides shall be allowed for backfill. Slope of the earth bank (ratio of excavated height to width) should be considered in order to avoid collapse of earth (Table C.1).

Table C.1 - Maximum excavation slope on various grounds

Kind of soil	Ratio of height to width
Sandy soil	1:1
Clayey sandy soil	1:0.67
Clayey soil	1:0.50
Clay	1:0.33
Soil with gravel	1:0.67
Dry loess	1:0.25

C.1.2 Foundation of the digester should be made of cobbles or crushed stones, and tamped before pouring of concrete.

C.2 Backfilling of the digester:

C.2.1 For loose soil, the mixture of the backfill should be 30% gravel or broken stones and 70% soil. Water content in the backfilled soil should be about 20 %– 25%.

C.2.2 Each layer of backfill outside the wall should be compacted.

C.2.3 The backfill area should be well sloped to allow easy drainage of surface water. Grass and plants but not trees, should be grown on the backfilled area.

Annex D
(informative)

Parts of biogas plant

D.1 Parts of Floating type plant with external guide frame: 1. Collecting pit, 2. Digester, 3. Gas chamber, 4. Slurry store, 5. Gas pipe, 6. Fill pipe, 7. Guide frame

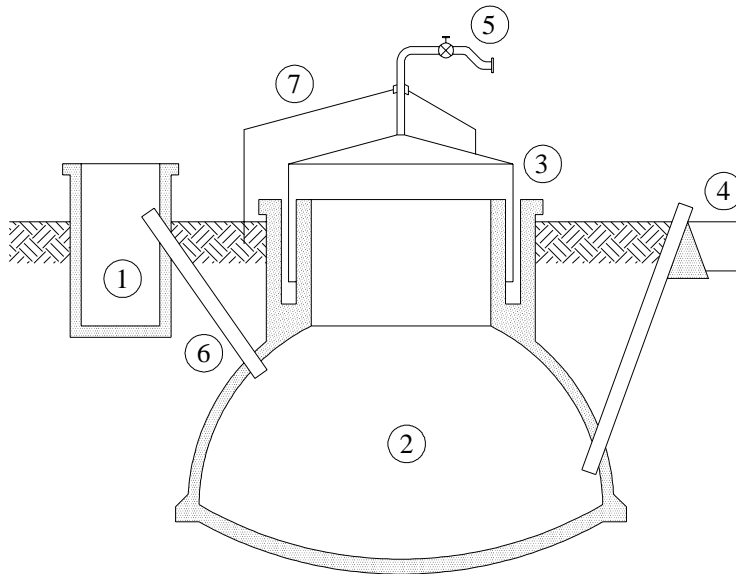

D.2 Parts of Fixed type plant: 1. Collecting tank with inlet pipe and sand trap, 2. Digester, 3. Compensation and removal tank, 4. Gas chamber, 5. Gaspipe, 6. Entry hatch, with gas tight seal, 7. Accumulation of thick sludge, 8. Outlet pipe, 9. Reference level, and 10. Supernatant scum, broken up by varying level.

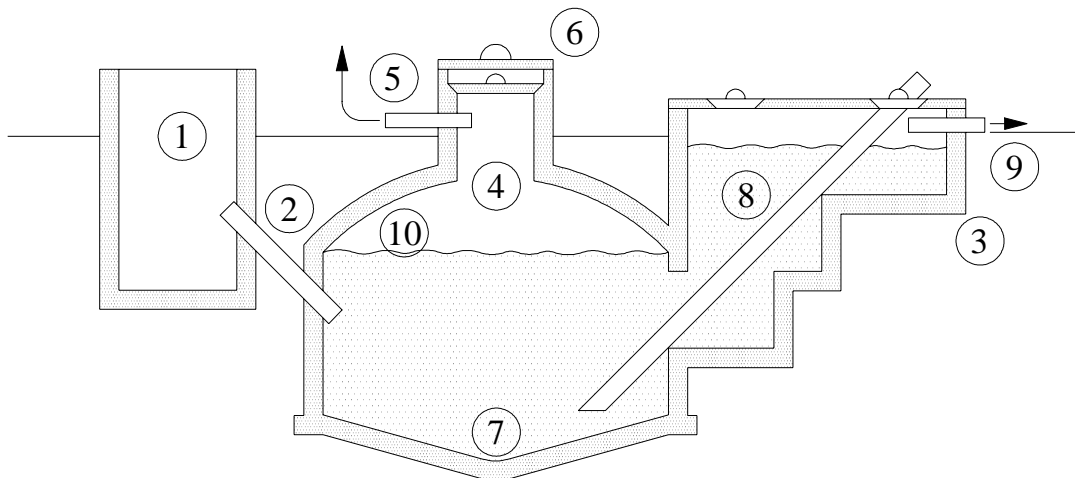

D.3 Parts of Balloon type plant: 1. Inlet, 2. gas pipe, 3. Gas chamber, 4. Slurry volume and 5. Outlet pipe

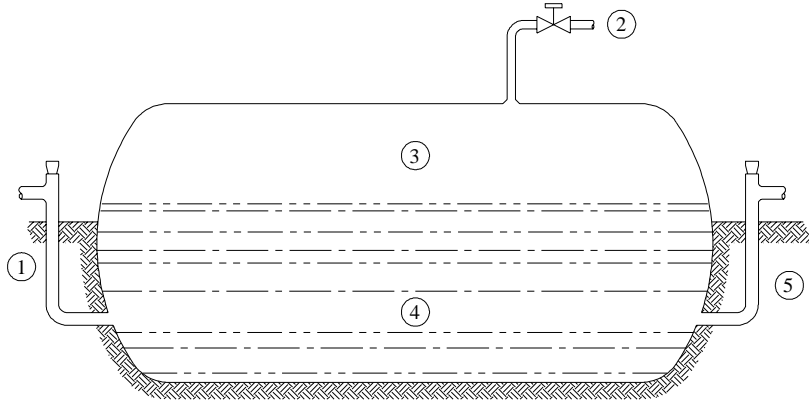

Annex E
(informative)

**Formula used in calculating the dimensions
(with 15% freeboard)**

E.1 Digester**E.1.1 Floating type****E.1.1.1 Cylindrical digester**

$$\text{Inner diameter, } D_d = \sqrt[3]{\frac{4.6 \times V_d}{\pi \times r}}$$

$$\text{Digester Height} = rD_d$$

where: V_d = effective digester volume, m^3
 r = height/diameter ratio

E.1.1.2 Square digester

$$\text{Inner side of the square digester, } S_d = \sqrt[3]{\frac{1.15 \times V_d}{r}}$$

$$\text{Digester Height} = rS_d$$

where: V_d = effective digester volume, m^3
 r = height/diameter ratio

E.1.1.3 Rectangular digester

$$\text{Inner width of rectangular digester, } W_d = \sqrt[3]{\frac{1.15 \times V_d}{r \times p^2}}$$

$$\text{Digester Height} = rL_d$$

where: V_d = effective digester volume, m^3
 r = height/diameter ratio
 p = desired width and length proportion

E.1.2 Fixed type**E.1.2.1 Cylindrical digester**

$$\text{Total height, m} = 1.2 \sqrt[3]{\frac{4r^2 V_d}{\pi}}$$

where: V_d = effective digester volume, m^3
 r = height/diameter ratio

E.1.2.2 Square digester

$$\text{Total height} = 1.2 \sqrt[3]{r^2 V_d}$$

where: V_d = effective digester volume, m^3
 r = height/diameter ratio

E.1.2.3 Rectangular digester

$$\text{Total height} = 1.2 \sqrt[3]{pr^2 V_g}$$

where: V_d = effective digester volume, m^3
 r = height/diameter ratio
 p = desired width and length proportion

E.2 Gas chamber (Floating type)**E.2.1 Cylindrical gas chamber**

$$\text{Inner diameter of gas chamber, } D_g \text{ (m)} = \frac{45 \times D_d - w}{50}$$

$$\text{height of pyramidal roof, } h \text{ (m)} = \frac{D_g \times \tan 9.5^\circ}{2}$$

$$\text{height of gas chamber, } H_g \text{ (m)} = 1.15 \left(\frac{4V_g}{\pi D_g^2} + H_p \right)$$

where: D_d = inner diameter of digester, m
 V_g = effective gas chamber volume, m^3
 H_p = desired pressure head, m
 w = gas chamber wall thickness, cm

E.2.2 Square/Rectangular gas chamber

$$\text{Inner length of gas chamber, } L_g \text{ (m)} = \frac{45 \times L_d - w}{50}$$

$$\text{Inner width of gas chamber, } W_g \text{ (m)} = \frac{45 \times W_d - w}{50}$$

$$\text{height of pyramidal roof, } h \text{ (m)} = \frac{W_g \times \tan 9.5^\circ}{2}$$

$$\text{height of gas chamber wall, } H_g \text{ (m)} = 1.15 \left(\frac{V_g}{L_g W_g} + H_p \right)$$

where: L_d = inner length of rectangular digester, m
 W_d = inner width of rectangular digester, m
 H_p = desired pressure head, m
 w = gas chamber wall thickness, cm

NOTE 1 If the gas chamber is made of steel sheets, wall thickness is insignificant

NOTE 2 $L_g = W_g$ and $W_g = S_g$ for square cross-section

E.2.3 Water-sealed gas chamber (upper part of the digester is double-walled)

$$\text{Inner length of gas chamber, } L_g \text{ (m)} = \frac{55 \times L_d + t}{50}$$

$$\text{Inner width of gas chamber, } W_g \text{ (m)} = \frac{55 \times W_d + t}{50}$$

$$\text{Inner diameter of gas chamber, } D_g \text{ (m)} = \frac{55 \times D_d + t}{50}$$

where: L_d = inner length of rectangular digester, m
 W_d = inner width of rectangular digester, m
 D_d = inner diameter of digester, m
 t = digester wall thickness, cm

E.2.4 Distance of retainer

Distance of the retainer below the top of the digester wall = $0.13 \times \text{ht. of digester} + 0.87(\text{ht. of gasholder} - \text{desired pressure head})$

Annex F
(informative)

**Sample calculation for the design
and utilization of floating-drum plant**

F.1 Mixing chamber

Given:

Number of swine (36-55 kg): **10**

Amount of manure produced: **52.2 kg**
One swine produces 5.22 kg/day (Table 1)

Total slurry input: **104.2 kg**
Using 1:1 ratio of manure and water

Find: Volume of mixing tank 0.104 m^3
 $104.2 \text{ kg} / 1000 \text{ kg/m}^3 = 0.104 \text{ m}^3$

Dimension of square tank

Given:

$r = 0.5$, from Table 3

Find: Inner side

$$\text{Inner side} = \sqrt[3]{\frac{1.15(0.104)}{0.5}} = 0.62 \text{ m}$$

including 15% freeboard

$$\text{height} = rS_d = 0.5(0.62) = 0.31 \text{ m}$$

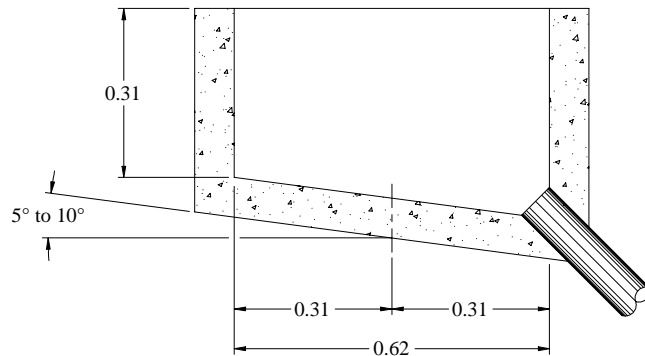

NOTE Dimensions are in meters

Figure F.1 – Mixing chamber

F.2 Digester tank

Volume of the digester tank required, V: 2.6 m^3

Total input multiply by retention time (Table 2), 25 days x 0.104 m^3 of manure mixture

Dimension of rectangular digestion tank:

Given:

$$r = 0.455$$

$$L = 1.2W$$

Find: Dimension of Digester

$$\text{Width, } W = \sqrt[3]{\frac{1.15 \times 2.6}{0.455 \times 1.2^2}} = 1.66 \text{ m}$$

$$L = 1.2W = 1.2 \times 1.66 = 2 \text{ m}$$

$$H = rL = 0.455(2) = 0.91 \text{ m}$$

Find: Height of the baffle board, minimum

$$\text{filling line} = \text{height of the digester} - \text{freeboard} = 0.91(1-.15) = 0.77 \text{ m}$$

$$(25-50\% \text{ of the filling line}) = 0.77 \times 0.25 = 0.19 \text{ m}$$

F.3 Gasholder

Given:

52.2 kg manure

1 kg manure produces 0.058 m³ (Annex B, Table B.4) for 25 days retention time

$$\text{volume of gas/day} = 52.2 \times 0.058 = 3.5 \text{ m}^3$$

Assume: Biogas utilization for one day (Annex J)

Light (ordinary)

$$2 \text{ light} \times 3 \text{ hr} \times 0.071 \text{ m}^3/\text{hr} = 0.426 \text{ m}^3/\text{day}$$

Stove (5 cm)

$$1 \text{ stove} \times 3 \text{ hr} \times 0.226 \text{ m}^3/\text{hr} = 0.678 \text{ m}^3/\text{day}$$

Refrigerator (0.01 m³)

$$1 \text{ ref.} \times 24 \text{ hr} \times 0.053 \text{ m}^3/\text{hr} = \underline{1.272 \text{ m}^3/\text{day}}$$

$$\text{TOTAL} \quad \quad \quad \underline{2.376 \text{ m}^3/\text{day}}$$

Gas to be stored:

$$3.5 - 2.376 = 1.124 \text{ m}^3 \times 130\% \text{ for biogas fluctuation} = 1.46 \text{ m}^3$$

$$\text{Volume of gas} = 1.46 \text{ m}^3$$

Find: Dimension of gasholder

Assume the desired pressure head to be maintained within the gasholder is 20 cm

$$\text{Length of gasholder} = 45 \times 3.2/50 = 2.88 \text{ m}$$

$$\text{Width of gasholder} = 45 \times 2.7/50 = 2.43 \text{ m}$$

Height of gasholder wall = $1.15 [1.46/(1.8 \times 1.44) + 0.2] = 0.88 \text{ m}$

Height of gasholder roof = $(1.44 \times \tan 9.5)/2 = 0.12 \text{ m}$

Length of gas retainer
(11% of inner digester length) = $0.11 \times 2 = 0.22 \text{ m}$

distance of the retainer
below the top of the digester wall = $0.13 \times 0.91 + 0.87(0.88 - 0.2) = 0.71 \text{ m}$

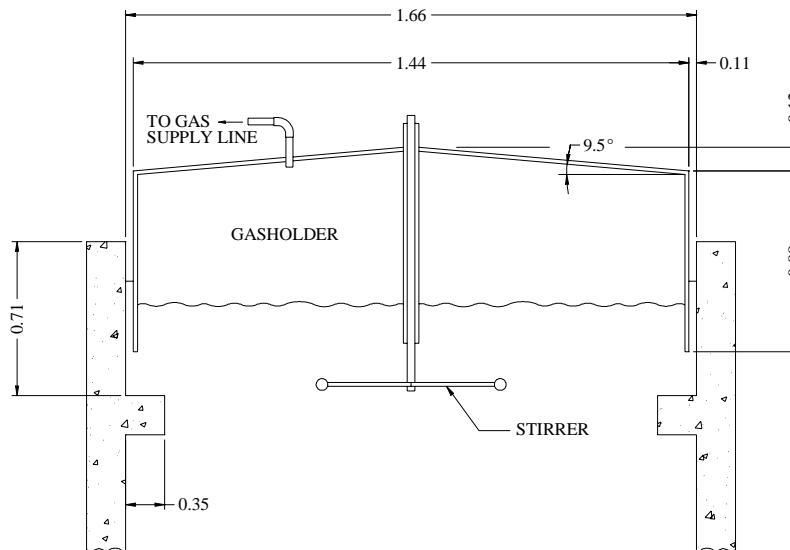

Figure F.2 – Floating drum gasholder

F.4 Outlet chamber

Dimensions are the same as the inlet chamber

Location of pipes

- upper inlet pipe should be 20 cm above the filling line or 0.97 m from the digester floor and the lower is located below the gas retainer
- upper end should be 20 cm above the filling line and the lower end of the pipe should be 10 cm above the floor

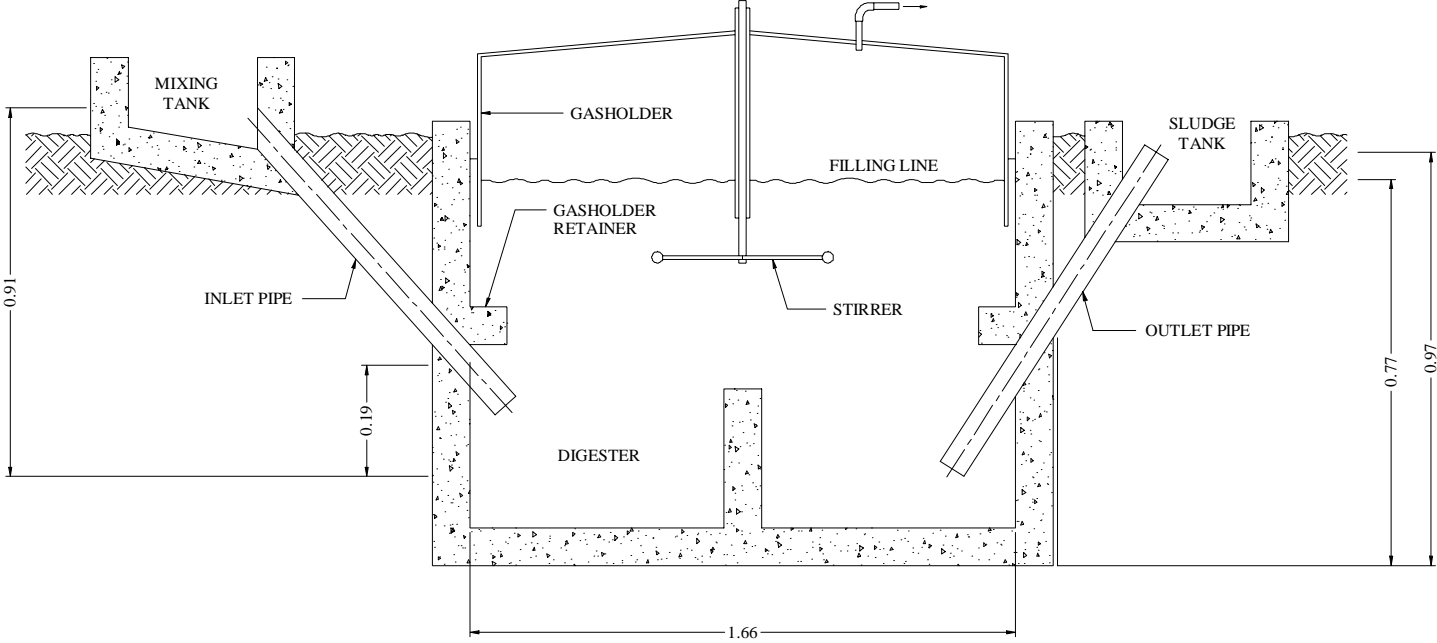

Figure F.3 – Dimension of a floating type biogas plant

ANNEX G
(informative)

Typical design of other biogas plant

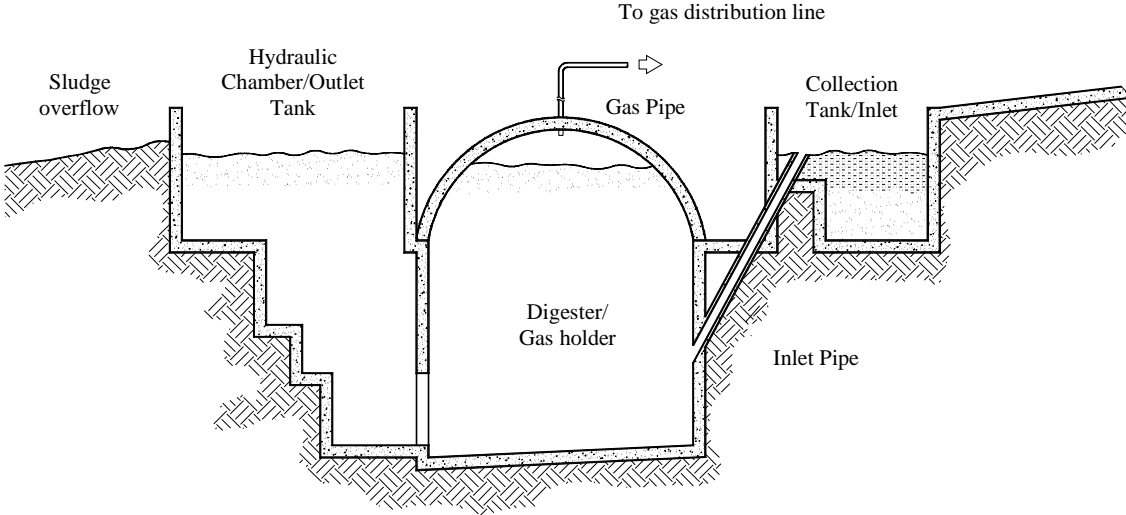

Figure G.1 - Square/Rectangular fixed-dome digester

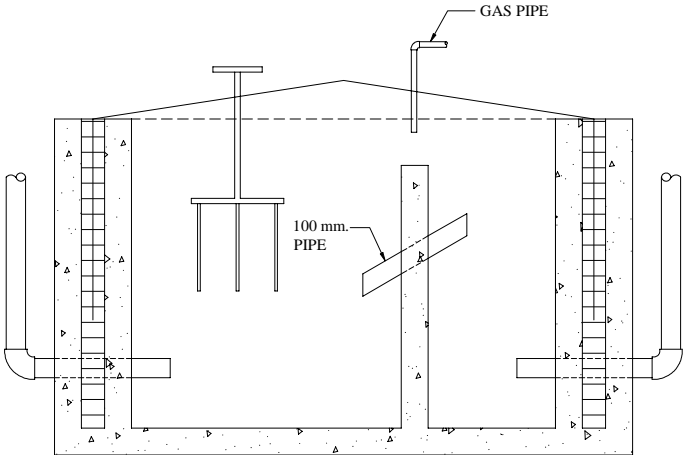

Figure G.2 - Two chamber rectangular digester with floating gas chamber and water seal

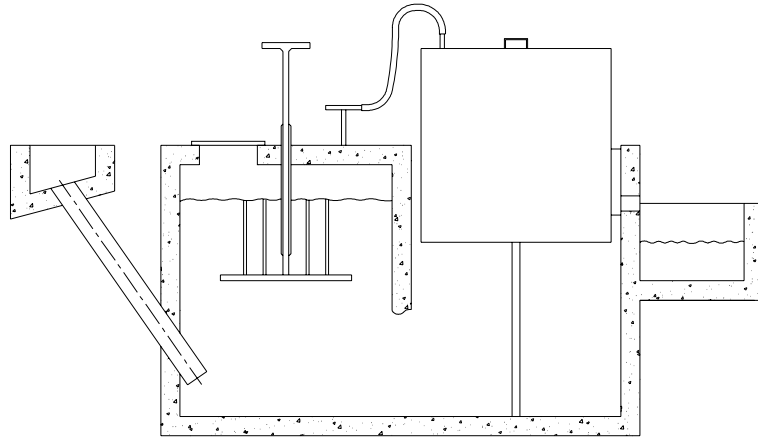

Figure G.3 - Two chamber rectangular digester with floating gas chamber

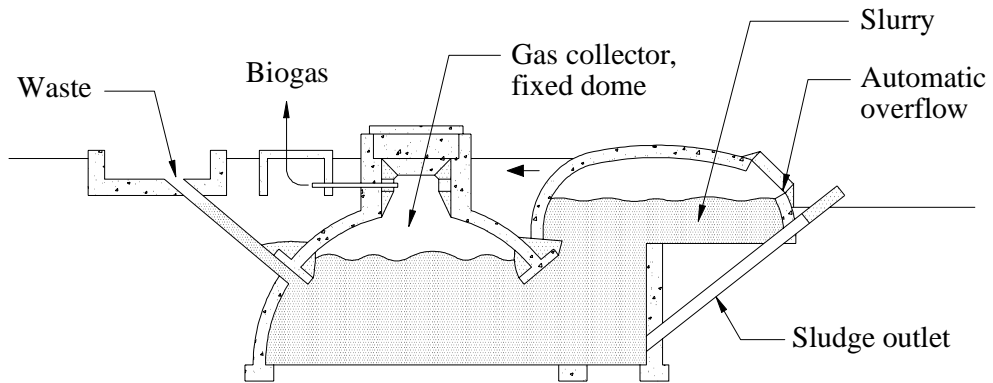

Figure G.4 - Fixed dome plant CAMARTEC design

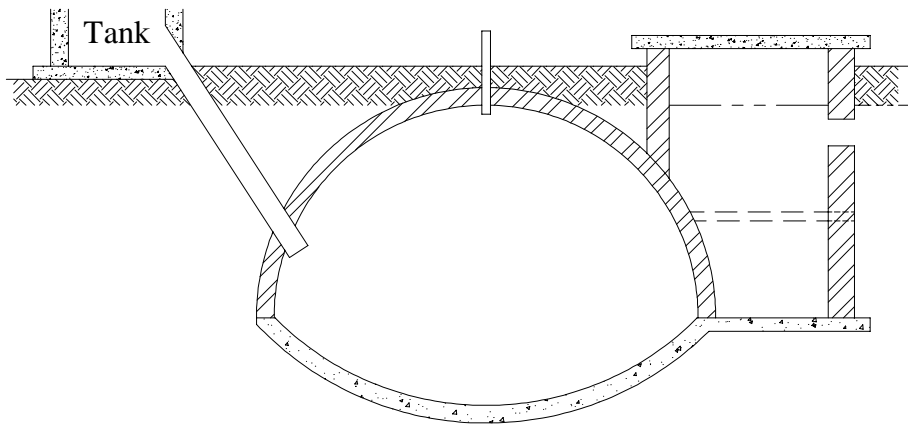

Figure G.5- Fixed dome plant Deenbandhu design

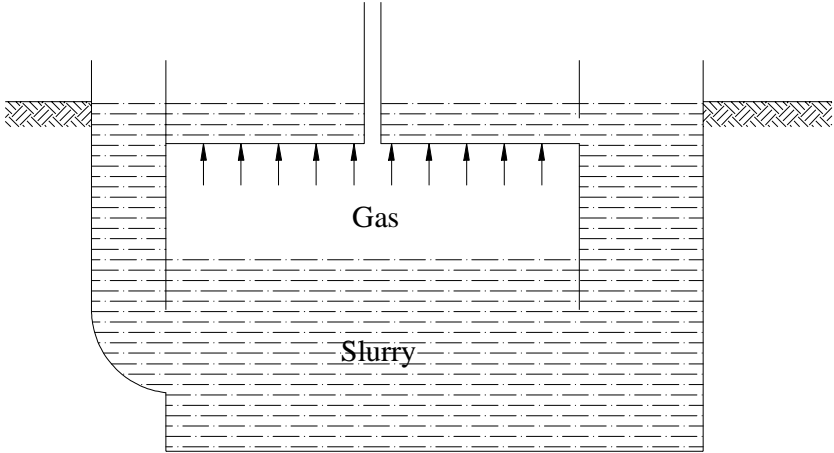

Figure G.6 - Square fixed dome digester

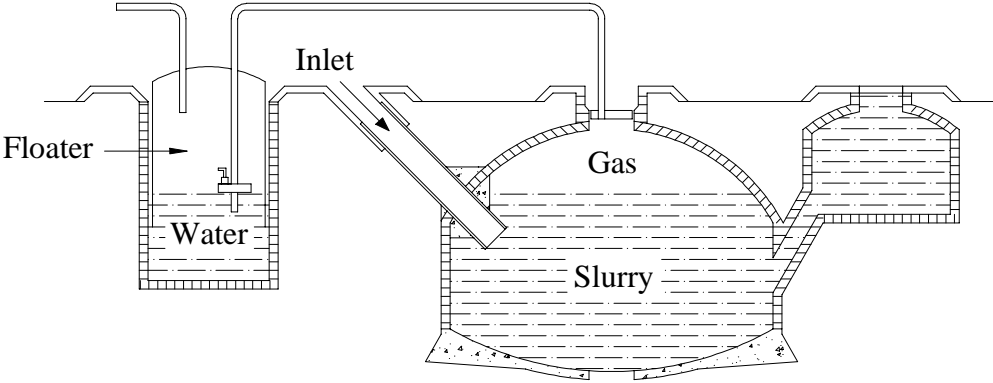

Figure G.7 - Fixed Dome digester with separate gas chamber

Annex H
(informative)

Typical agitation method

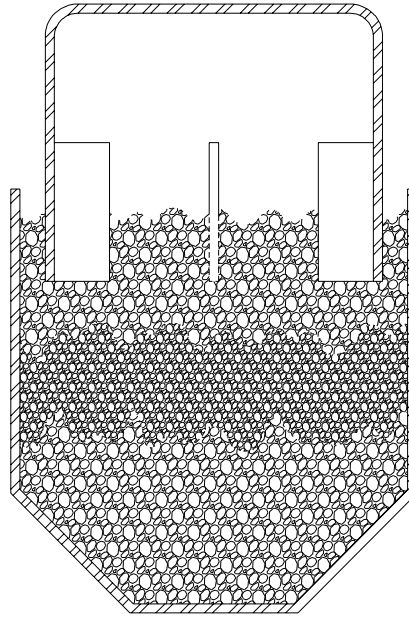

Figure H.1 - Mixing substrate by vanes

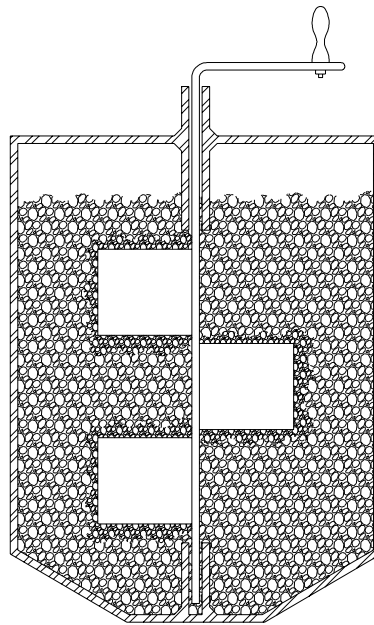

Figure H.2 - Mixing substrate by hand agitation

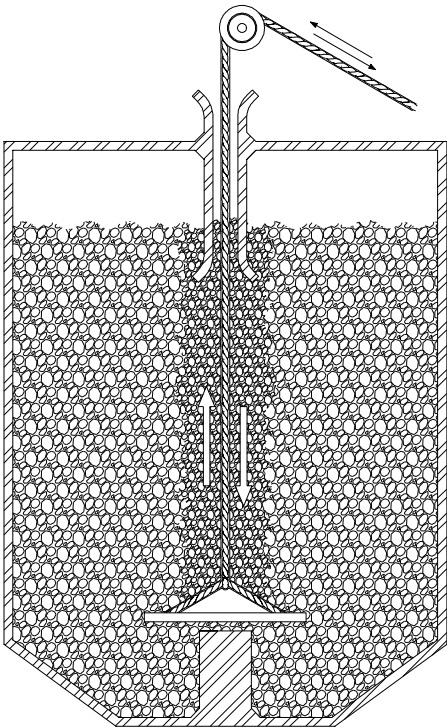

Figure H.3 - Mixing substrate by rope agitation

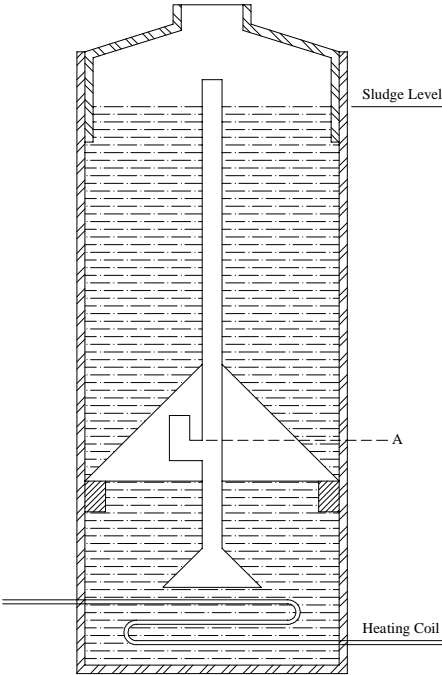

Figure H.4 - Mixing substrate by biogas-powered agitation

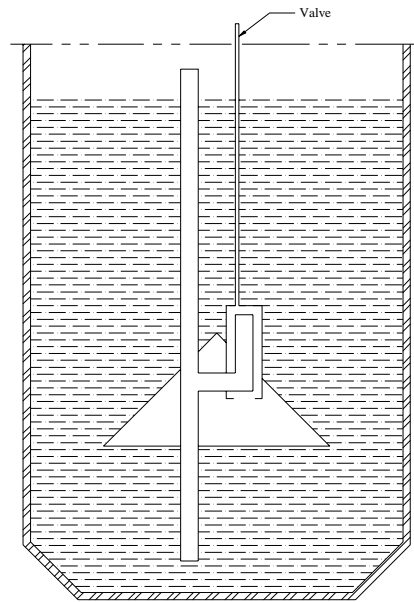

Figure H.5 - Mixing substrate by modified gas-powered agitation

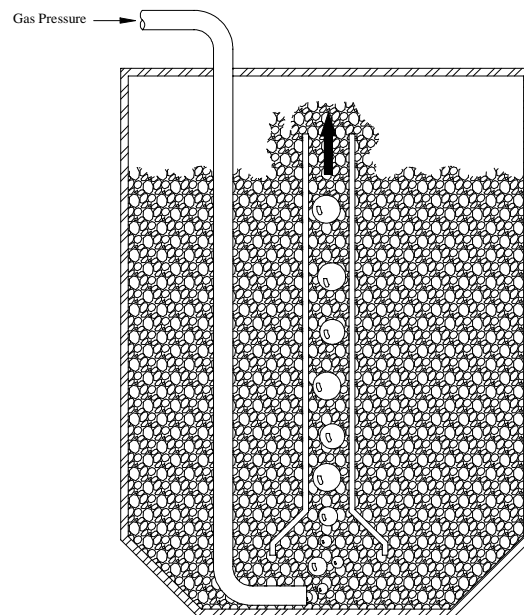

Figure H.6 - Mixing substrate by bubble pump

Annex I
(informative)

Operation and maintenance

I.1 Initial loading

I.1.1 Starter/Seeding

The initial raw materials should contain slurry with a high bacteria population. About 5-10% of the total slurry volume should be added when the digester is about 25% full.

I.1.2 Filling the digester

Before putting any slurry into digester. All valves should be open. Mix the manure and water thoroughly and fill the digester up to the ring level or top beam. Do not add any new slurry to the digester until at least three days after combustible gas is produced.

I.2 Mixing slurry for regular loading

About one liter of water should be added to every kilo of manure and it should be thoroughly mixed until the right consistency is obtained.

I.3 Regular loading of input materials and removal of effluent from outlet chamber

The loading of materials should be done regularly. The amount of slurry to be loaded should be in accordance with the requirement of the particular digester volume and its retention time. The loading of new slurry displaced an equal volume of effluent to the outlet chamber which should be removed.

I.4 Stirring/Agitation

If stirring is necessary, it should be done daily: three minutes in the morning and three minutes in the afternoon. The stirring should be 360 degrees in one direction, then 360 degrees in the opposite direction.

I.6 Servicing scum

All gas within the digester should be released and the gas piping closest to the digester should be disconnected.

I.7 Periodic cleaning of the digester

The digester should be emptied at intervals to remove the settled sludge and other inorganic solids that accumulate at the bottom of the digester.

I.8 Repairing masonry work within the digester

If the digester is damaged in the form of cracks or leaks, the damaged area should be repaired. The edges of the damaged area should be cleaned and roughened. Two to three layers of chicken wire should be attached to the walls with nails at least 30 cm from either side of the crack. The plastering cement-sand (1:3) mortar should be at least 13 mm thick. The finish should be roughened and should be allowed to dry for at least two weeks. Wax/paraffin seal should be applied.

I.9 Entering the digester

When entering a digester which has been used, the manhole should be removed for several days and gas line closest to the digester should be disconnected. The contents should be removed and the tank should be ventilated. Before entering, presence of harmful gasses or sufficient air should be first checked. Flames should be avoided near or within the digester. A piece of pipe or hose through which the worker inside the pit may breath should be provided. Another person should be constantly watching from the outside of the pit that can respond to any emergency.

Annex J
(informative)

Gas requirements for some appliances

Appliance	Type	Gas requirements m ³ /hr
Gas burner 5 cm 10 cm 14 cm	Non-continuous	0.226 0.28 0.42
Mantle lamp Ordinary 25-watt equivalent 60-watt equivalent	Non-continuous	0.071 0.100 0.195
Gas refrigerator 0.01 m ³ 0.17 m ³ 0.225 m ³	Continuous	0.053 0.067 0.078
Incubator (per m ³ capacity)	Continuous	0.600
Gasoline engine Per kW output Per rated kW	Non-continuous	0.569 0.398
Diesel engine Per kW output Per rated kW	Non-continuous	0.700 0.563